

RoHS

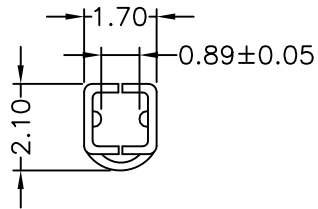
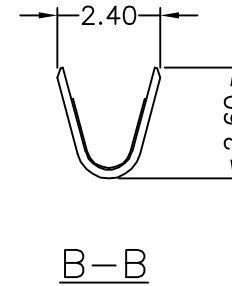
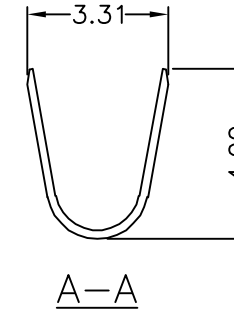
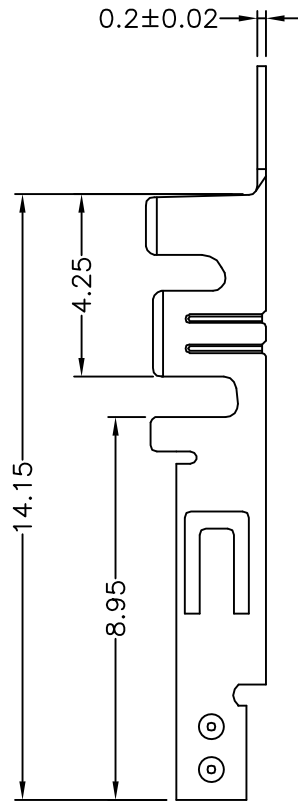
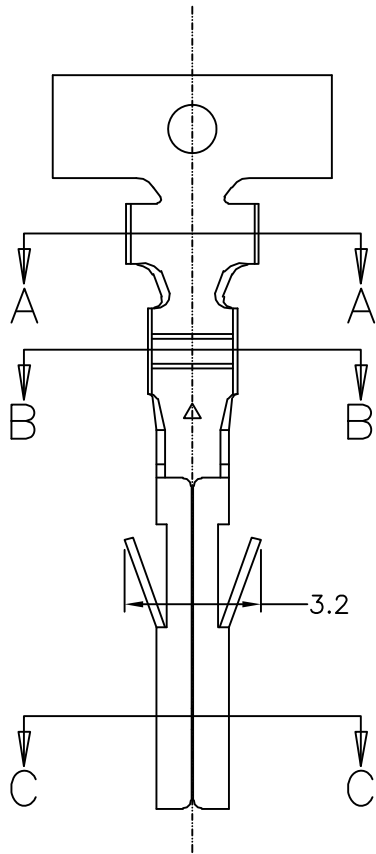

Part No.	Wire Range	Insulation O.D.	Material	Finish	Q'ty/Reel
C4202T2B-2	AWG 16#~22#	3.10mm(Max)	Brass	Tin-Plated	5,000
C4202T2P-2	AWG 16#~22#	3.10mm(Max)	Phos.bronze	Tin-Plated	5,000

Note: e-Stamping before Tin-plated or Gold-flash

REVISION RECORD				
REV.	DATE	DESCRIPTION	CHANGE	APPROVE

TOLERANCE	DRAW	比例	SCALE	1:1
.0±0.25	DESIGN	比例	UNIT	mm
0.00±0.20	CHECK	符号	SIZE	A4
0.000±0.15	APPROVE	符号	SHEET	1/1
	VERSION	ZL1	PROJ.	

UNC 耀聯電子科技有限公司
UNC Electronic & Technology Co., Ltd

PART NO. C4202T2X-2
DESCRITON 4.20mm PITCH
DRAWING NO. CRIMP TERMINAL-FEMALE, MINI-FIT