

RoHS

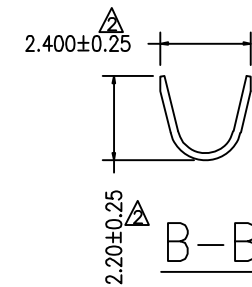
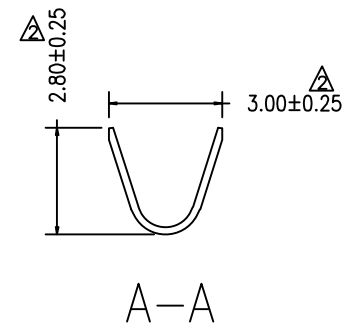
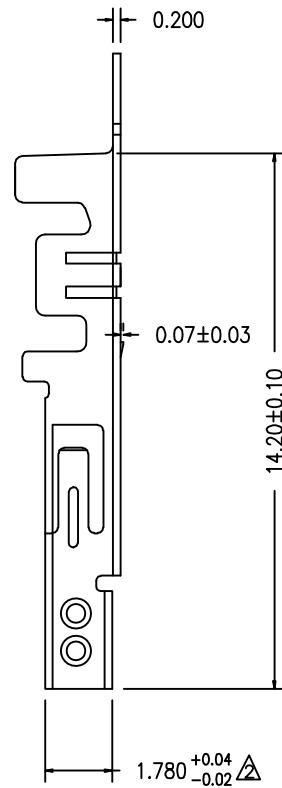
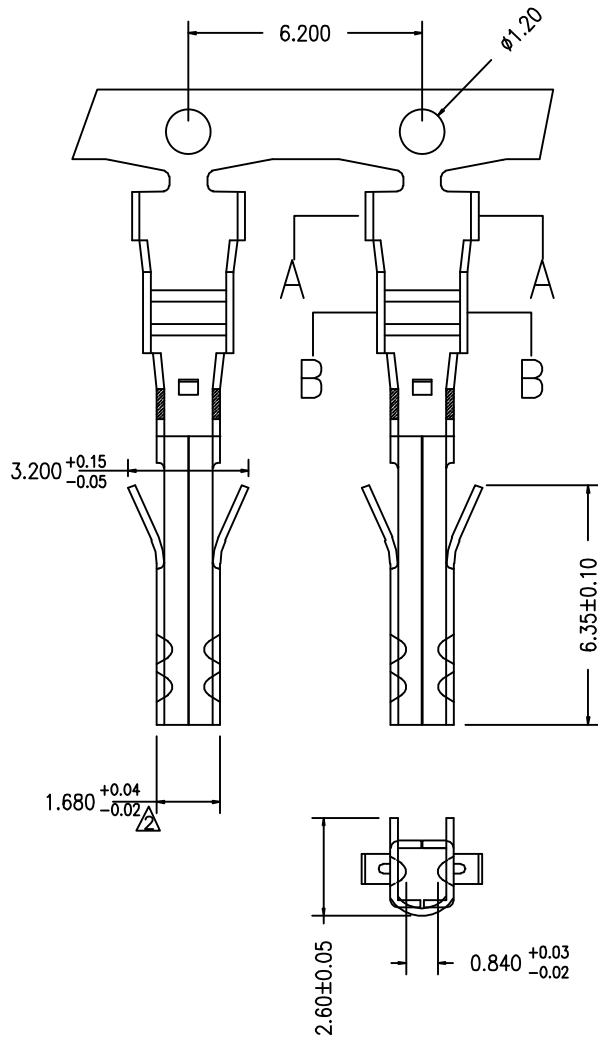

Part No.	Wire Range	Insulation O.D.	Material	Finish	Q'ty/Reel
C4202TOB-2	AWG 18#~22#	2.70mm(Max)	Brass	Tin-Plated	10,000
C4202TOP-2	AWG 18#~22#	2.70mm(Max)	Phos.bronze	Tin-Plated	10,000

Note: e-Stamping before Tin-plated or Gold-flash

REVISION RECORD

REV.	DATE	DESCRIPTION	CHANGE	APPROVE
2	2017-11-21	修正公差	ZHU	CHUN

TOLERANCE
 .0±0.25
 0.00±0.20
 0.000±0.15

DRAW	旭德	SCALE	1:1
DESIGN	旭德	UNIT	mm
CHECK	陈春	SIZE	A4
APPROVE	陈春	SHEET	1/1
VERSION	ZL.2	PROJ.	☉

UNC 耀聯電子科技有限公司
 UNC Electronic & Technology Co., Ltd

PART NO. C4202TOX-2
 DESCRITON 4.20mm PITCH
 CRIMP TERMINAL-FEMALE,
 MINI-FIT
 DRAWING NO.

TEL:0769-87299998 FAX:0769-87299968 E-Mail:uniconn@163.com WEB:http://www.uniconn.cn