

REV.	ECN NO. OR DESCRIPTION	REVISED	DATE
A1			2020-10-20

SPECIFICATIONS:
 1. Current Rating: 3A AC,DC
 2. Voltage Rating: 250V AC,DC
 3. Temperature Range: -25°C ~ +85°C
 4. Contact Resistance: 20mΩ Max.
 5. Insulation Resistance: 1000MΩ Min.
 6. Withstanding Voltage: 250V AC/minute
 7. Suitable C2531 Series Terminal
 8. Mates With c2532 Series Housing
 9. Material:
 HSG: Nylon66 94V-0

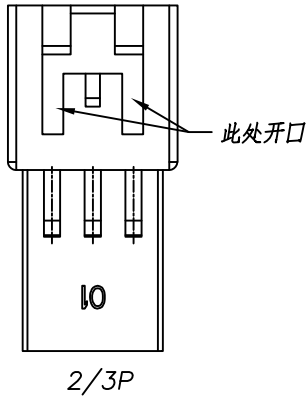

Circuits	Dimensions		
	A	B	C
2	2.50	6.10	7.90
3	5.00	8.60	10.40
4	7.50	11.10	12.90
5	10.00	13.60	15.40
6	12.50	16.10	17.90
7	15.00	18.60	20.40
8	17.50	21.10	22.90
9	20.00	23.60	25.40
10	22.50	26.10	27.90
11	25.00	28.60	30.40
12	27.50	31.10	32.90
13	30.00	33.60	35.40
14	32.50	36.10	37.90
15	35.00	38.60	40.40

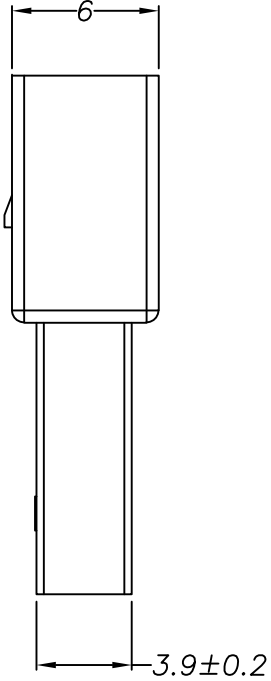
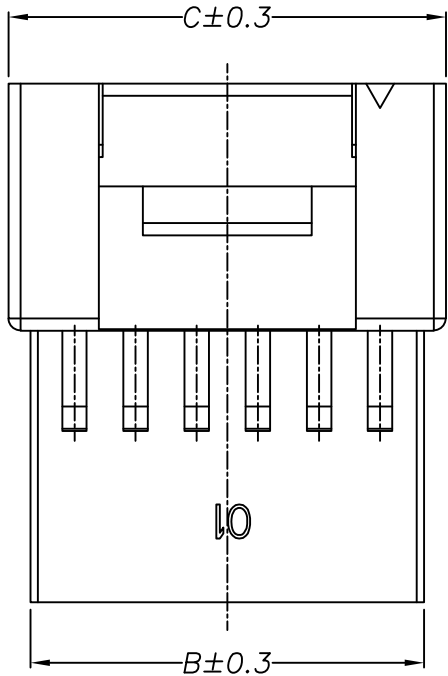
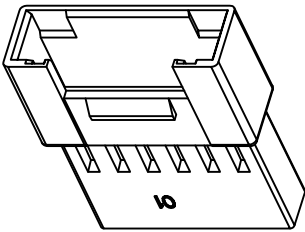
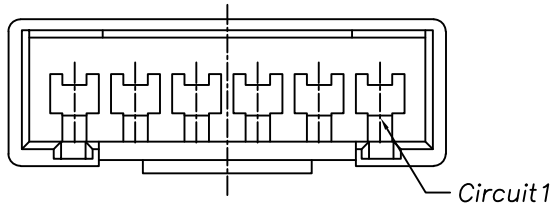
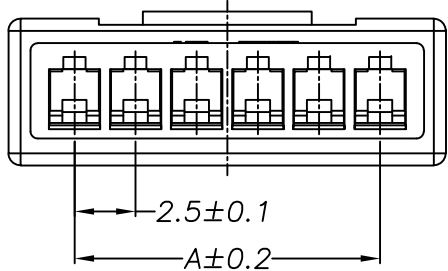

TOLERANCE	DRAW	BO	SCALE	1:5	UNC 耀聯電子科技有限公司 <small>UNC Electronic & Technology Co., Ltd</small>	
	DESIGN	MA	UNIT	mm		
X :±0.3	CHECK	LIAN	SIZE	A4	PART NO.	C2531H00-NP
X.X :±0.25	APPROVE	LIAN	SHEET	1of1	DESCRIPTION	SMH250-HSG
X.XX :±0.15	VERSION	J1	PROJ.			
X.XXX :±0.10	TEL:+86-769-87299998		WEB:http://www.uniconn.cn		MAIL:uniconn@163.com	

Non-use Warranty for Level 1 Prohibited Substances In Product.

