

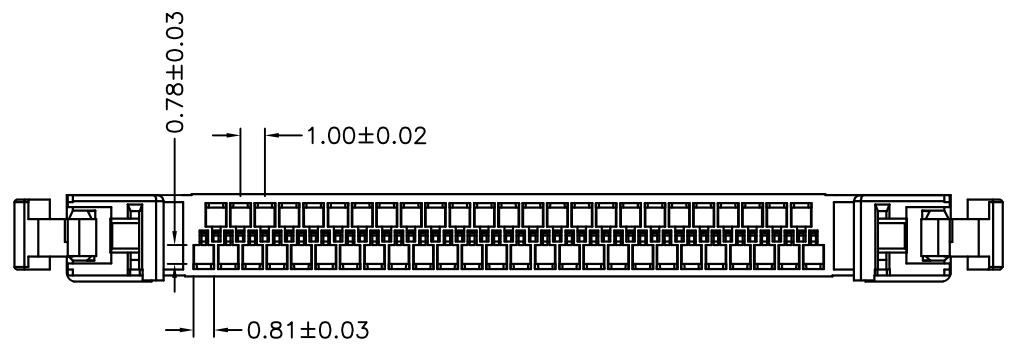

1 2 3 4 5 6 7 8 9 10

A0505HS0-XP-HL
 $\angle X=41/51$

	A	B
51P	32.60	36.25
41P	27.60	31.25

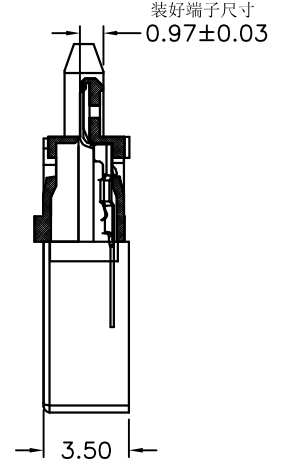
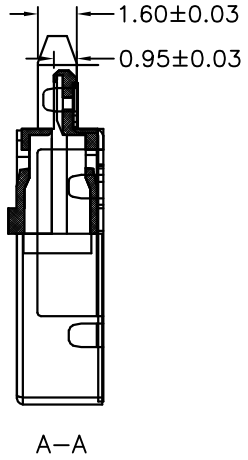
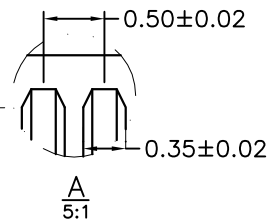
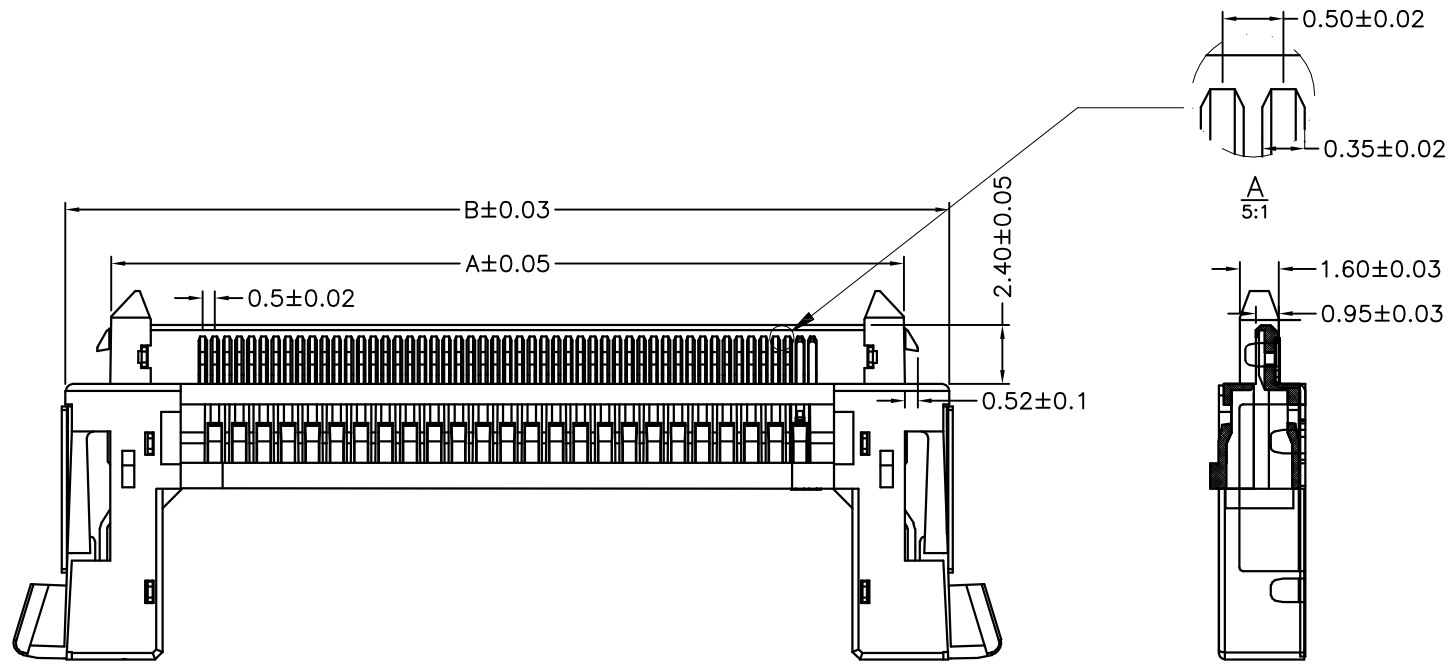

SPECIFICATIONS
 Current Rating: 1A AC,DC
 Voltage Rating: 100V AC,DC
 Temperature Range: $-25^{\circ}\text{C} \sim +85^{\circ}\text{C}$
 Contact Resistance: 50m Ω Max.
 Insulation Resistance: 100M Ω Min.
 Withstanding Voltage: 500V AC/minute
 Material:
 Housing: LCP,UL94V-0,Black
 Shell: SUS304,T=0.20mm
 Lock lever: SUS304,T=0.30mm
 Q'ty: 50/Tray

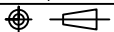
REVISION RECORD					TOLERANCE	DRAW	SCALE	1:1	 耀聯電子科技有限公司 UNC Electronic & Technology Co., Ltd	
REV.	DATE	DESCRIPTION	CHANGE	APPROVE						
					.0±0.25	DESIGN	UNIT	mm	PART NO.	A0501HS0-XP-HL
					0.00±0.15	CHECK	SIZE	A4	DESCRITON	FI-RE 0.5 HOUSING
					0.000±0.08	APPROVE	SHEET	1/1	DRAWING NO.	A0501.dwg
						VERSION	PROJ.			
					TEL:0769-87299998 FAX:0769-87299968		E-Mail:uniconn@163.com		WEB:http://www.uniconn.cn	

1 2 3 4 5 6 7 8 9 10